

# EYP-ECL-0770-00018-1500-BFY12-0005

Revision 0.51

2025-07-25

## SINGLE FREQUENCY LASER External Cavity Diode Laser



### General Product Information

Product	Application
770 nm mini-ECL	Spectroscopy (K D1 line)
with hermetic 14-Pin Butterfly Housing (RoHS compliant)	Metrology
including Monitor Diode, Thermoelectric Cooler and Thermistor	Quantum Technology
with integrated $\mu$ -Isolator and PM Fiber	

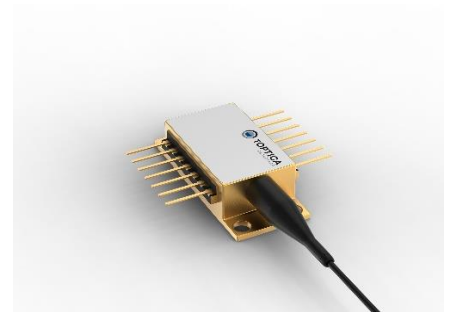

### Absolute Maximum Ratings

Parameter	Symbol	Unit	min	typ	max
Storage Temperature	$T_S$	$^{\circ}\text{C}$	-40		85
Operational Temperature at Case	$T_C$	$^{\circ}\text{C}$	-40		85
Operational Temperature at Chip	$T_{\text{chip}}$	$^{\circ}\text{C}$	-5		50
Forward Current	$I_F$	mA			200
Reverse Voltage	$V_R$	V			2
Output Power	$P_{\text{opt}}$	mW			25
TEC Current	$I_{\text{TEC}}$	A			1.4
TEC Voltage	$V_{\text{TEC}}$	V			4.8

### Measurement Conditions / Comments

Stress in excess of one of the Absolute Maximum Ratings may damage the laser. Please note that a damaging optical power level may occur although the maximum current is not reached. These are stress ratings only, and functional operation at these or any other conditions beyond those indicated under Recommended Operational Conditions is not implied.

### Recommended Operational Conditions

Parameter	Symbol	Unit	min	typ	max
Operational Temperature at Case	$T_{\text{case}}$	$^{\circ}\text{C}$	-20		65
Operational Temperature at Chip	$T_{\text{chip}}$	$^{\circ}\text{C}$	0		45
Forward Current	$I_F$	mA			180
Output Power	$P_{\text{opt}}$	mW	5		18

### Measurement Conditions / Comments

measured by integrated Thermistor

# EYP-ECL-0770-00018-1500-BFY12-0005

Revision 0.51

2025-07-25

## SINGLE FREQUENCY LASER External Cavity Diode Laser



### Characteristics Tchip = 25 °C at BOL

Parameter	Symbol	Unit	min	typ	max
Center Wavelength	$\lambda_C$	nm	769	770	771
Target Wavelength	$\lambda_T$	nm		770.11	
Linewidth	$\Delta\lambda$	MHz		0.1	0.3
Mode-hop free Tuning Range	$\Delta\lambda_{\text{tune}}$	pm		15	
Output Power	$P_{\text{opt}}$	mW			18
Sidemode Suppression Ratio	SMSR	dB	30	45	
Temp. Coefficient of Wavelength	$d\lambda / dT$	nm/K		0.008	
Current Coefficient of Wavelength	$d\lambda / dI$	nm/mA		0.001	
Laser Current	$I_{LD}$	mA			180
Slope Efficiency	$\eta$	mW/mA		0.2	
Threshold Current	$I_{th}$	mA		60	
Polarization Extinction Ratio	PER	dB		20	

Measurement Conditions / Comments

reached within Tchip = 0 °C ... 45 °C  
measured in the time scale of 1 ms  
By current tuning, at target wavelength

Popt = 18 mW

Popt = 18 mW

### Monitor Diode

Parameter	Symbol	Unit	min	typ	max
Monitor Detector Responsivity	$I_{\text{mon}} / P_{\text{of}}$	$\mu\text{A}/\text{mW}$		10	

Measurement Conditions / Comments

5 V

### Thermoelectric Cooler

Parameter	Symbol	Unit	min	typ	max
Current	$I_{\text{TEC}}$	A		0.4	
Voltage	$U_{\text{TEC}}$	V		1.5	
Power Dissipation (total loss at case)	$P_{\text{loss}}$	W		0.5	
Temperature Difference	$\Delta T$	K			50

Measurement Conditions / Comments

Popt = 18 mW,  $\Delta T = 20$  K

Popt = 18 mW,  $\Delta T = 20$  K

Popt = 18 mW,  $\Delta T = 20$  K

Popt = 18 mW,  $\Delta T = |T_{\text{case}} - T_{\text{chip}}|$

### Thermistor (Standard NTC Type)

Parameter	Symbol	Unit	min	typ	max
Resistance	R	k $\Omega$		10	
Beta Coefficient	b			3892	
Steinhart & Hart Coefficient A	A			$1.1293 \times 10^{-3}$	
Steinhart & Hart Coefficient B	B			$2.3410 \times 10^{-4}$	
Steinhart & Hart Coefficient C	C			$8.7755 \times 10^{-8}$	

Measurement Conditions / Comments

Tchip = 25 °C

$R_1/R_2 = e^{b(1/T_1 - 1/T_2)}$  at Tchip = 0 ... 50 °C

$1/T = A + B(\ln R) + C(\ln R)^3$

T: Temperature in Kelvin

R: resistance at T in  $\Omega$

# EYP-ECL-0770-00018-1500-BFY12-0005

Revision 0.51

2025-07-25

## SINGLE FREQUENCY LASER External Cavity Diode Laser



### Pin Assignment

1	Thermoelectric Cooler (+)	14	Thermoelectric Cooler (-)
2	Thermistor	13	Case
3	Photo Diode Anode	12	not connected
4	Photo Diode Cathode	11	Laser Diode Cathode
5	Thermistor	10	Laser Diode Anode
6	not connected	9	not connected
7	not connected	8	not connected

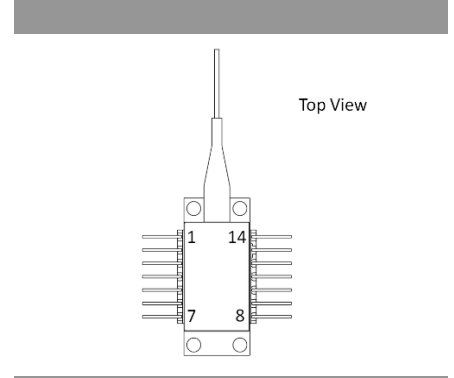

### Package Drawings

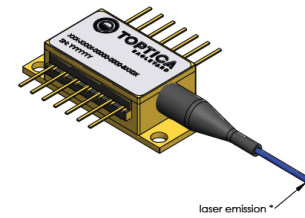
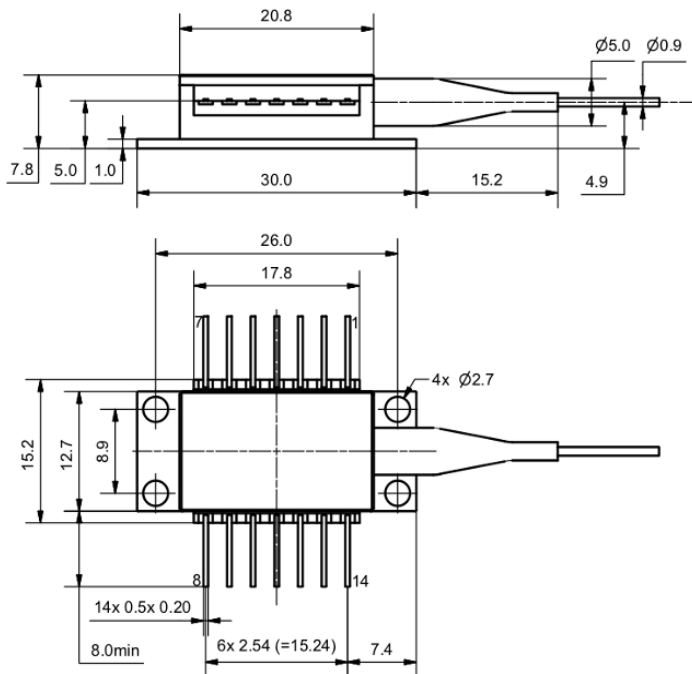

\* For properties of fiber pigtail and connector type please see P/N specification sheet

AIZ-16-0222-1415

# EYP-ECL-0770-00018-1500-BFY12-0005

Revision 0.51

2025-07-25

## SINGLE FREQUENCY LASER External Cavity Diode Laser



### Fiber and Connector Type (Output)

Parameter	
PM Fiber	900 / 125 / 5.5 $\mu\text{m}$ , UV/Polyester-elastomer Coating ( $l = 1 \pm 0.1 \text{ m}$ )
Connector	FC/APC (narrow key / 2mm)

### Measurement Conditions / Comments

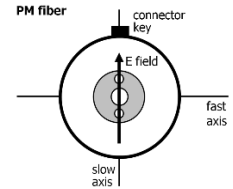

# EYP-ECL-0770-00018-1500-BFY12-0005

Revision 0.51

2025-07-25

## SINGLE FREQUENCY LASER External Cavity Diode Laser



### Unpacking, Installation and Laser Safety

Unpacking the laser diodes should only be done at electrostatic safe workstations (EPA). Though protection against electro static discharge (ESD) is implemented in the laser package, charges may occur at surfaces. Please store this product in its original package at a dry, clean place until final use. During device installation, ESD protection has to be maintained.

A laser diode is sensitive against optical feedback, so an optical isolator may be required in order to avoid any disturbance of the emission spectrum. Operating at moderate temperatures on proper heat sinks will contribute to a long lifetime of the diode.

Avoid direct and/or indirect exposure to the free running beam. Collimating and focussing the free running beam with optics as common in optical instruments will increase threat to the human eye.

Each laser diode will come with an individual test protocol verifying the parameters given in this document.

Performance figures, data and any illustrative material provided in this specification are typical and must be specifically confirmed in writing by eagleyard Photonics before they become applicable to any particular order or contract. In accordance with the eagleyard Photonics policy of continuous improvement specifications may change without notice.

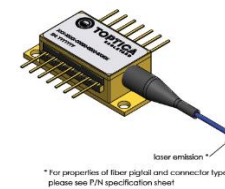

\* For properties of fiber physical and connector type please see P/N specification sheet

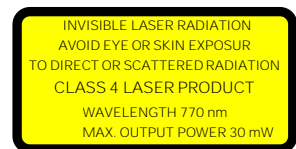

IEC-60825-1



Complies with 21 CFR 1040.10 and 1040.40