

EYP-DFB-0852-00100-1500-BFW01-0005

Revision 0.94

2025-07-07

SINGLE FREQUENCY LASER DFB Laser



General Product Information

Product	Application
852 nm DFB Laser	Spectroscopy (Cs D2 line)
with hermetic 14 Pin-Butterfly Housing (RoHS compliant)	Metrology
including Monitor Diode, Thermoelectric Cooler and Thermistor	Atomic Clock
with integrated Beam Collimation	

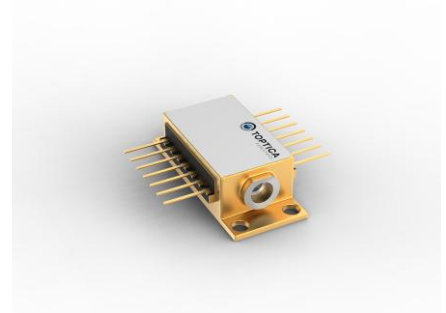

Absolute Maximum Ratings

Parameter	Symbol	Unit	min	typ	max
Storage Temperature	T_S	°C	-40		85
Operational Temperature at Case	T_C	°C	-40		85
Operational Temperature at Chip	T_{chip}	°C	10		55
Forward Current	I_F	mA			200
Reverse Voltage	V_R	V			2
Output Power	P_{opt}	mW			110
TEC Current	I_{TEC}	A			1.4
TEC Voltage	V_{TEC}	V			3.2

Measurement Conditions / Comments

Stress in excess of one of the Absolute Maximum Ratings may damage the laser. Please note that a damaging optical power level may occur although the maximum current is not reached. These are stress ratings only, and functional operation at these or any other conditions beyond those indicated under Recommended Operational Conditions is not implied.

Recommended Operational Conditions

Parameter	Symbol	Unit	min	typ	max
Operational Temperature at Case	T_{case}	°C	0		65
Operational Temperature at Chip	T_{chip}	°C	15		50
Forward Current	I_F	mA			170
Output Power	P_{opt}	mW	20		100

Measurement Conditions / Comments

if operated at target wavelength
Popt must not exceed 100 mW

EYP-DFB-0852-00100-1500-BFW01-0005

Revision 0.94

2025-07-07

SINGLE FREQUENCY LASER DFB Laser



Characteristics Tchip = 25° at BOL

Parameter	Symbol	Unit	min	typ	max
Center Wavelength	λ_C	nm	851	852	853
Target Wavelength	λ_T	nm		852.347	
Linewidth	$\Delta\lambda$	MHz		0.6	1
Mode-hop free Tuning Range	$\Delta\lambda_{\text{tune}}$	pm	25		
Sidemode Suppression Ratio	SMSR	dB	30	50	
Temp. Coefficient of Wavelength	$d\lambda / dT$	nm/K		0.06	
Current Coefficient of Wavelength	$d\lambda / dI$	nm/mA		0.003	
Laser Current	I_{LD}	mA			170
Slope Efficiency	η	mW/mA		0.8	
Threshold Current	I_{th}	mA			70
Divergence parallel	$\Theta_{ }$	°		0.1	
Divergence perpendicular	Θ_{\perp}	°		0.1	
Beam Diameter horizontal	$d_{ }$	mm		1.0	1.2
Beam Diameter vertical	d_{\perp}	mm		0.8	1.2
Degree of Polarization	DOP	%		90	

Measurement Conditions / Comments
reached within Tchip = 15° ... 50° C at 100 mW
Popt = 100 mW
> 10 GHz, at target wavelength
Popt = 100 mW
at Popt = 100 mW
parallel to the base plate of the housing
perpendicular to base plate of the housing
parallel to the base plate of the housing
perpendicular to base plate of the housing
Popt = 100 mW; E field parallel to the base plate

Monitor Diode

Parameter	Symbol	Unit	min	typ	max
Monitor Detector Responsivity	$I_{\text{mon}} / P_{\text{of}}$	$\mu\text{A}/\text{mW}$	0.5		10

Measurement Conditions / Comments
5 V reverse voltage

Thermoelectric Cooler

Parameter	Symbol	Unit	min	typ	max
Current	I_{TEC}	A		0.4	
Voltage	U_{TEC}	V		1.3	
Power Dissipation (total loss at case)	P_{loss}	W		0.4	
Temperature Difference	ΔT	K			50

Measurement Conditions / Comments
Popt = 100 mW, $\Delta T = 20$ K
Popt = 100 mW, $\Delta T = 20$ K
Popt = 100 mW, $\Delta T = 20$ K
Popt = 100 mW, $\Delta T = T_{\text{case}} - T_{\text{chip}} $

Thermistor (Standard NTC Type)

Parameter	Symbol	Unit	min	typ	max
Resistance	R	k Ω		10	
Beta Coefficient	b			3892	
Steinhart & Hart Coefficient A	A			1.1293×10^{-3}	
Steinhart & Hart Coefficient B	B			2.3410×10^{-4}	
Steinhart & Hart Coefficient C	C			8.7755×10^{-8}	

Measurement Conditions / Comments
Tchip = 25° C
$R_1/R_2 = e^{\beta(1/T_1 - 1/T_2)}$ at Tchip = 0° ... 50° C

EYP-DFB-0852-00100-1500-BFW01-0005

Revision 0.94

2025-07-07

SINGLE FREQUENCY LASER DFB Laser



Pin Assignment

1	Thermoelectric Cooler (+)	14	Thermoelectric Cooler (-)
2	Thermistor	13	Case
3	Photo Diode Anode	12	not connected
4	Photo Diode Cathode	11	Laser Diode Cathode
5	Thermistor	10	Laser Diode Anode
6	not connected	9	not connected
7	not connected	8	not connected

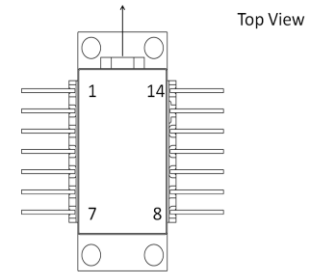

Package Drawings

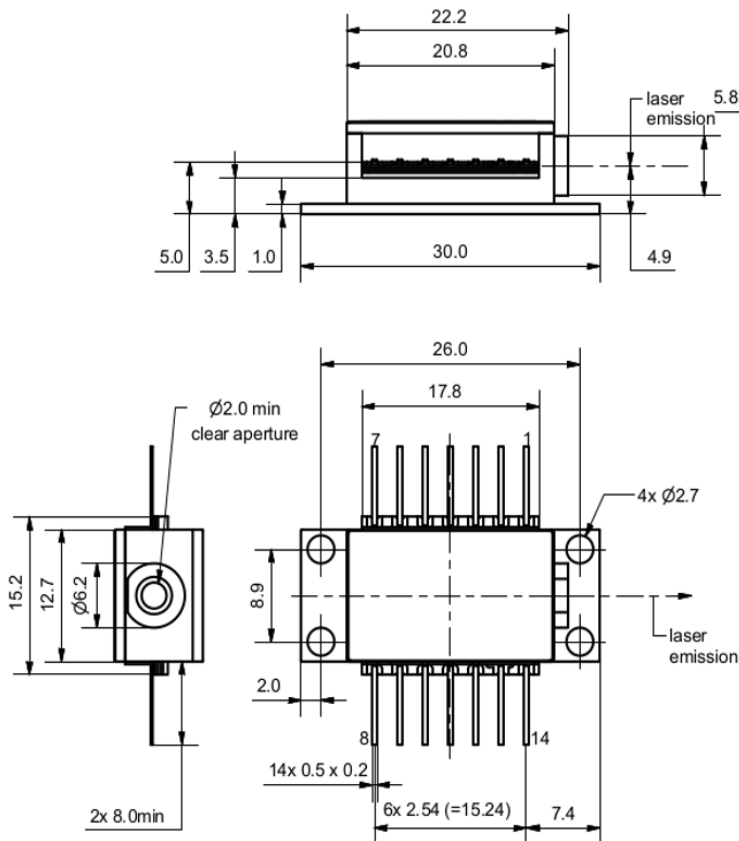
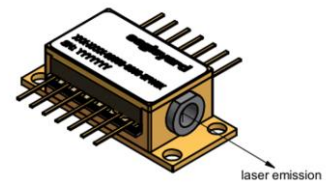

AIZ-20-1029-0928

EYP-DFB-0852-00100-1500-BFW01-0005

Revision 0.94

2025-07-07

SINGLE FREQUENCY LASER DFB Laser



Unpacking, Installation and Laser Safety

Unpacking the laser diodes should only be done at electrostatic safe workstations (EPA). Though protection against electro static discharge (ESD) is implemented in the laser package, charges may occur at surfaces. Please store this product in its original package at a dry, clean place until final use. During device installation, ESD protection has to be maintained.

A laser diode is sensitive against optical feedback, so an optical isolator may be required in order to avoid any disturbance of the emission spectrum. Operating at moderate temperatures on proper heat sinks will contribute to a long lifetime of the diode.

Avoid direct and/or indirect exposure to the free running beam. Collimating and focussing the free running beam with optics as common in optical instruments will increase threat to the human eye.

Each laser diode will come with an individual test protocol verifying the parameters given in this document.

Performance figures, data and any illustrative material provided in this specification are typical and must be specifically confirmed in writing by eagleyard Photonics before they become applicable to any particular order or contract. In accordance with the eagleyard Photonics policy of continuous improvement specifications may change without notice.

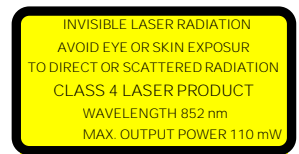

IEC-60825-1



Complies with 21 CFR 1040.10 and 1040.40